



(Designed & Manufactured by **RC EXPLORER TEAM**)

MS-Radon V2BT series Brushless Speed Control System User Guidelines

1. Technical /Specifications:

Model:	<i>MS-Radon V2BT</i>	
Continuous current:	105A	
Burst Current (10sec):	490A	
Battery Input:	3.7V LiPo	2cells
	1.2V NiMh/NiCd	4-6 cells
BEC Output:	Linear 6V/7.4V selection/~8A	
Weight (not include wiring & fan):	~22g	
Dimension(L x W x H) mm (Include the fan assembly to the ESC)	~31.5x25x15.5	
Motor limit with 2cell x 3.7V Lipo. Assume the motor timing is at 0 degree	6.5 Turn or over	

2. Features:

- * 32-bit MCU Processor with ultra-smooth & precise throttle and braking control
- * Compatible with sensored/sensorless brushless motors
- * Connect with Bluetooth device for advanced programming and firmware update through the Mobile APPS. APPS will be available on both IOS and Android
- * Real-Time Data Inspection through Mobile APPS(Current Input & Output Throttle, Temperature, RPM, Advanced Timing, Voltage and Min. Voltage, Max. Temperature, RPM & Adv. Timing)
- * Built-in one touch On/Off switch and support external On/Off switch
- * Built-in Low voltage cut-off, Overheat protection and Signal loss protection

3. Component Included:

- Speed control, Power capacitor, 20x20mm Fan, sensor wire

Noted: External Bluetooth Module are not included inside the package



4. Connection Diagram:

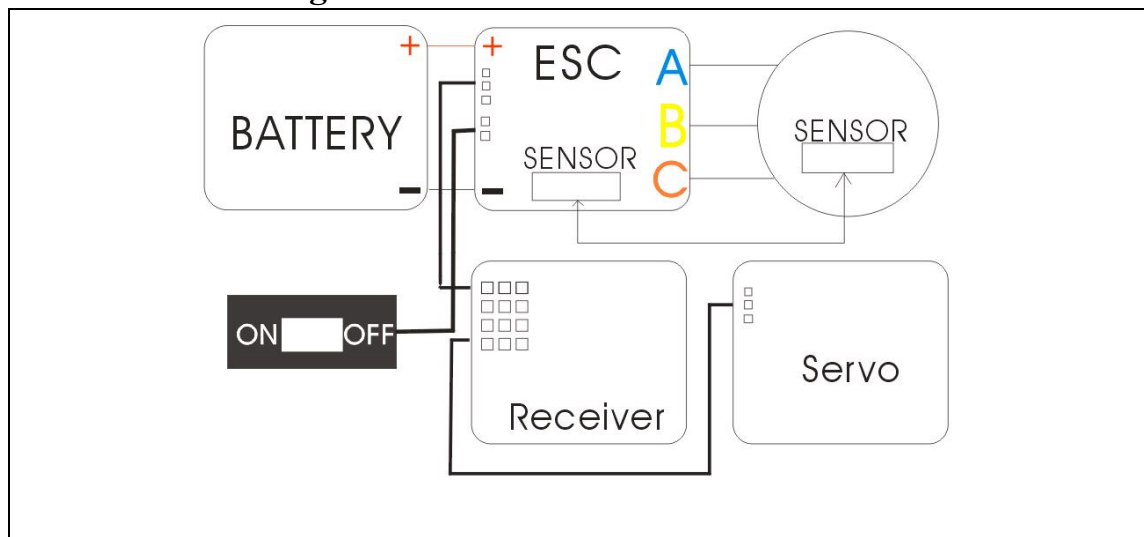

Installation Tips:

1. Connect the speed control **BEC wire at the back** to the receiver position channel 2.
2. Connect power wire “A” to the motor “A” solder-tabs
3. Connect power wire “B” to the motor “B” solder-tabs
4. Connect power wire “C” to motor “C” solder-tabs
5. Connect the hall sensor cable between the speed control (underneath the solder taps) and motor
6. Connect power wire “+” to battery “**Plus**” sign
7. Connect power wire “-” to battery “**Minus**” sign

Point to notes:

1. All power wires should be connected properly according to the **symbol** indicator and avoid creating solder bridges on the solder tab
2. Avoid soldering longer than 5sec per soldering joint when replacing the power wires on the speed control
3. When connecting the battery to the speed control, please make sure the battery + or – should be connected properly.
4. For the speed control BEC wire at the back, it can't be used to connect USB device to PC.
5. Please make sure to follow the above tips and notes to install the speed control, otherwise, the speed control may be destroyed due to the improper connection of the wires.



5. Speed Control Setup:

Step1: Transmitter Settings:

Before setup the speed control, please setup the following functions on your transmitter if available:

Functions description	Name in Radio	Setting Request
Throttle Travel	High ATV, EPA	100%
Brake Travel	Low ATV, EPA, ATL	100%
Throttle Exponential	EXP, EXPO	Set at 0
Neutral Trim	Sub Trim	Center
Servo Reverse	Throttle Reverse	Any setting, keep unchanged after the set-up procedure

If the transmitter does not have any of the above function, it is already in basic setup function.

Step 2: Set neutral, forward and brake endpoint data to the speed control:

- ⊙ Switch off the speed control power and please make sure the speed control is not connected to the battery.
- ⊙ Remove the motor gear to allow the wheels of the model are free to rotate.
- ⊙ Switch the transmitter on and move the transmitter throttle stick to the neutral position.
- ⊙ Connect the battery to speed control and press and hold the on/off button to turn on the unit until there is a Blue LED light up.
- ⊙ After release the on/off button, the Purple(Red+Blue LED) color is light up that mean the **throttle range setting** mode is entered and the neutral position has been set.
- ⊙ Move the throttle to the full throttle position, then the Purple color will be flashing until a solid Purple color will be light up. Solid Purple color represent the full throttle position has been set and one beep sound will be heard.



Step 2: cont...

- ⦿ Move the throttle stick to the full brake position, then the Purple color will be flashing until a solid Purple Color will be light up. Solid Purple color represent the full brake position has been set and two beep sounds will be heard.
- ⦿ Move the throttle stick back the neutral position again, then the flashing Purple color will be light up to Blue color that means **throttle range setting** has been completed. Three beep sounds will be heard and the speed control will be ready for use.

Step 3: Double check the speed control function:

The speed control can be checked based on the below LED status.

Functions	Status LED Color
Neutral	BLUE
Full Throttle	RED+ BLUE (Purple color)
Full Brake	RED

- ⦿ If the above LED status is correct corresponding to the speed control function, then the setup procedure has been completed and it is ready for using
- ⦿ If there is a mistake during the setup procedure. Please turn off the unit and repeat the Step 2 procedure.

In setup mode, the speed control will store the neutral, forward or brake position setting inside the built-in memory and will not lose even the battery is disconnected.

Notes:

If it can't enter to the "throttle range setting", please try to reverse the Throttle and Brake in the transmitter setting and go to step 2 to setup the speed control again.



6. LED Indicators:

- ⦿ If RED (Purple Light) LED is flashing for every 0.5s but keep light up the BLUE Led when the speed control is in the run, that mean the Low Voltage function is activated and the power to the motor reduce by ~50%. It shows the battery is lower than expected value.
- ⦿ If RED (Purple Light) LED is flashing twice for every 0.5s together when the speed control is in the run, that mean the Overheat Protection is activated, the speed control will cut ~50% power delivery to the motor to avoid the burning problem.
- ⦿ If BLUE LED keep blinking at neutral position, it indicates it is in Zero Timing /Blinking Mode.

7. Mobile APPS Connection to Speed Control Through Bluetooth:

Diagram A:

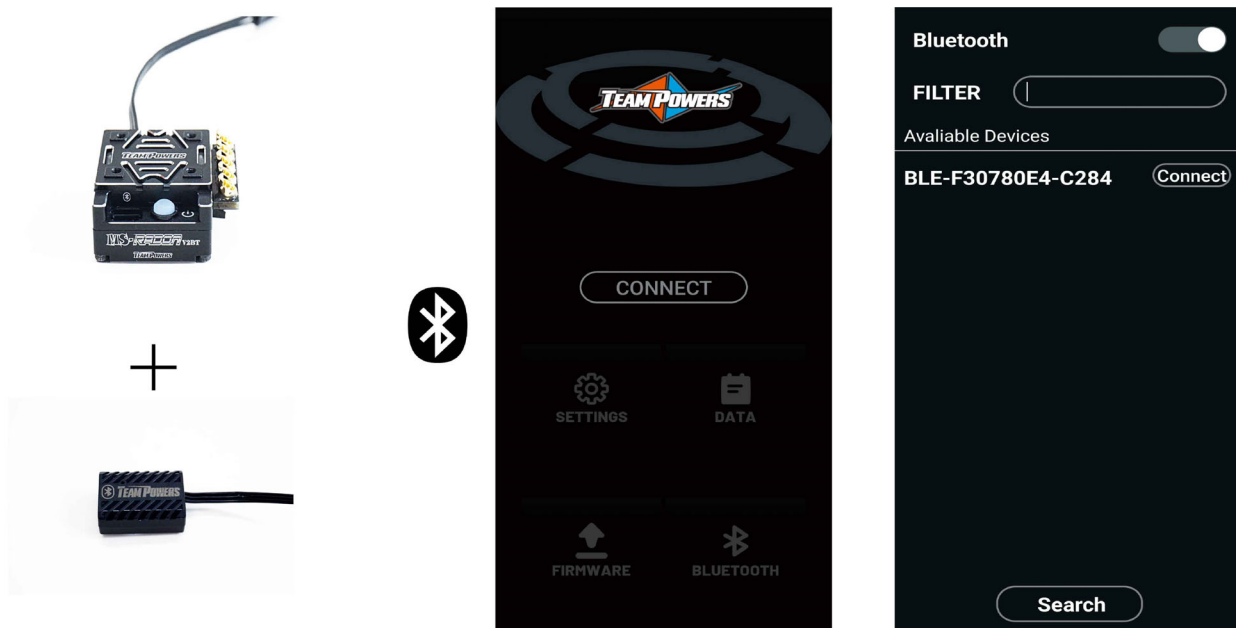
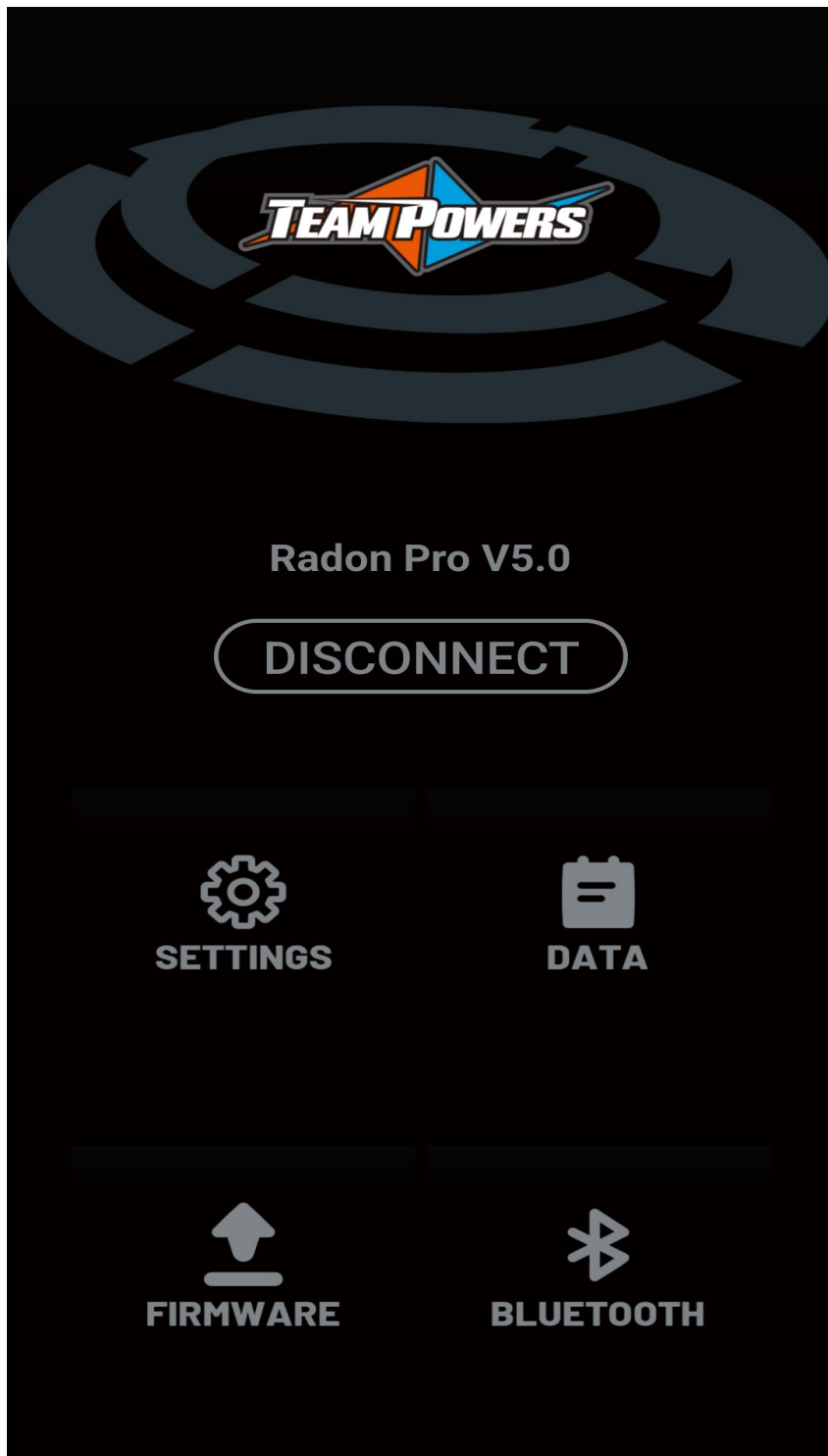



Diagram B:





Connection Procedures (Refer Diagram A):

1. Connect the Bluetooth device to speed control and turn on the speed control.
2. In mobile phone, open the APPS “TP_ESC-BT-V1” and Press “CONNECT” Button.
3. Press “Search” Button to find out the Bluetooth device with Pre-Fix “BLE” , then Press “Connect” . See Diagram A
4. Once the connection is completed, the screen on Diagram B will be shown up.

8. Speed Control Mobile Device(TP_ESC-BT-V1) APPS Main Menu:

A: Bluetooth Menu (Password Setup):

Diagram C:

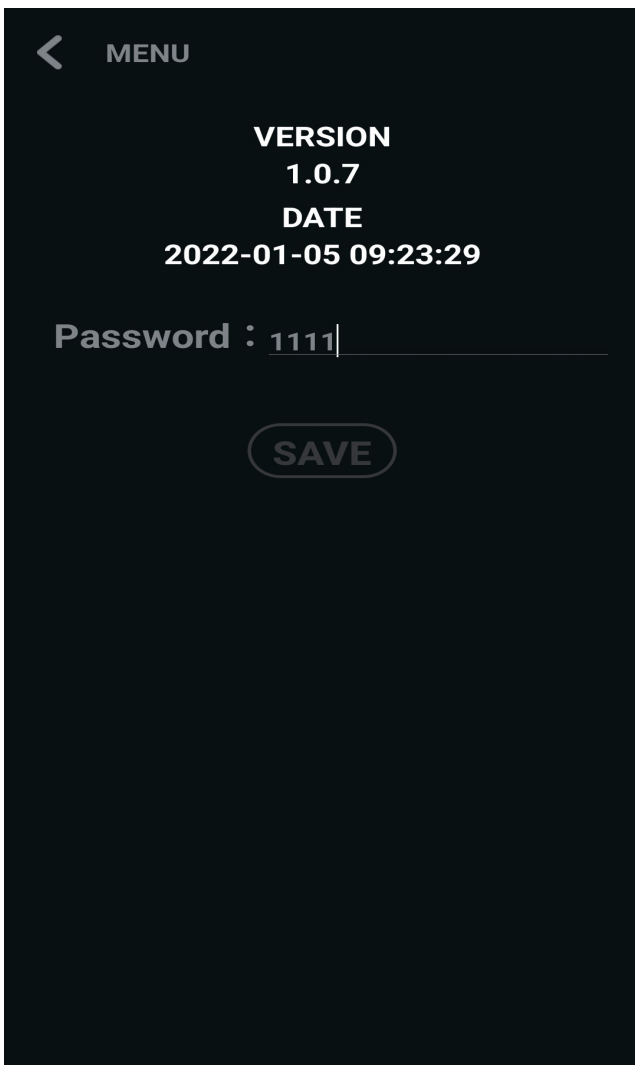



Set Password Procedures (Refer Diagram C):

1. Type the 4-digit new password and then Press “Save” . The default password is 0000.
2. When disconnect and re-connect the speed control through the Bluetooth again, it may need to re-enter the password to make sure the APPS connect the unique device matched to the password.

Notes: To set this password is to avoid different users can connect to the same speed control.

B: Data Menu:

It will show all the real-time data figure when the speed control is in operation.

< MENU	
Input Throttle	0.0%
Output Throttle	0.0%
Voltage	0.0V
Min. Voltage	0.0V
Temperature	0.0deg
Max. Temperature	0.0deg
RPM	0.0kr/min
Max. RPM	0.0kr/min
Adv. timing	0.0deg
Max. timing	0.0deg



C: Firmware Upgrade Menu

Diagram D:

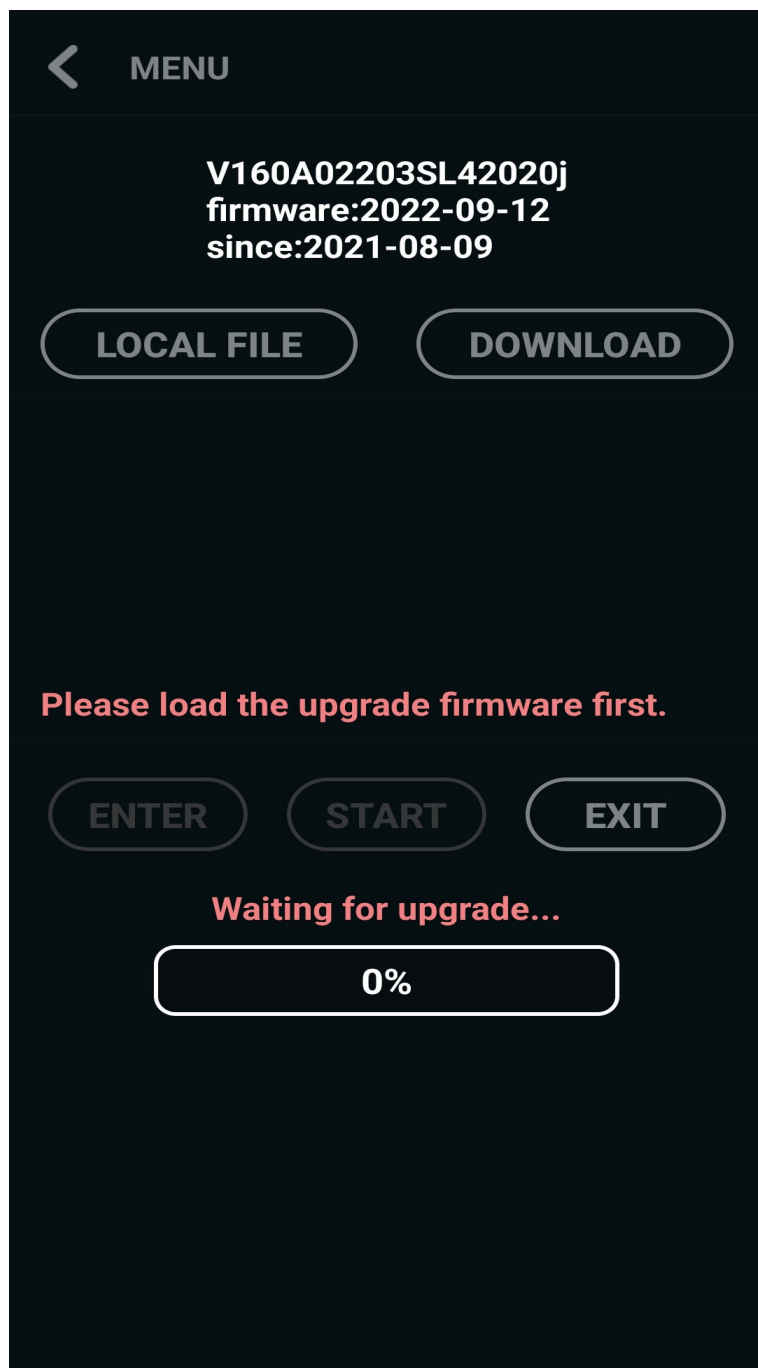



Firmware Update Procedures (Refer Diagram D):

1. Press “Download” to download the latest firmware from the cloud server provided by the factory.
2. After “Download Successful” is appeared, press “Enter” first then press “Start” to start upgrade firmware process. When in the upgrade process, the speed control Blue and Red LED keep flashing until Upgrading process is complete.
3. After the upgrade process is complete, the speed control Blue LED will be flashing for 0.5s and is ready for operate. Besides, press “Exit” Key to exit the firmware upgrade menu.

Firmware Update Procedures (Continue···)

Notes:

1. In case the “Start” key is pressed but the speed control stops working on upgrading process for some reasons, please try to re-connect the speed control to the APPS and go to Firmware Menu and press “Start” to restart the upgrading firmware process.
2. After the firmware update is completed, all items setting will be reset to factory default setup.
3. The “Local File” upgrade the firmware is not available yet.
4. The above menu is for android interface, for IOS interface it should have a little difference but with the same usage.



D: Setting Menu:

It includes 5 main sub-menu below. For each item usage and details, please refer to the “Radon Pro V5BT- ModeDescription” document.

MENU	
SAVE	DEFAULT
General	
Motor Rotation	*CCW
Motor Poles	*2.0P
Running Mode	Fwd/Brk/Rev
Rev. Delay	0.35s
Throttle Freq.	*8.0KHz
Low Voltage Cutoff	6.8V
Thermal Cutoff	*130deg
BEC Output	*6.0V

MENU	
SAVE	DEFAULT
Throttle	
Throttle Response	*0.1ms
Throttle Compr Rate	10.0%
Throttle Off Rate	*0(OFF)%
Dead Band	*3.0%
IP Limiter	10.0%
Limit Power	3.0%
Limit Power Range	60.0%
Max. Forward Force	*100.0%
Max. Reverse Force	25.0%

MENU	
SAVE	DEFAULT
Brake	
Brake Response	*0.1ms
Brake Rate	*1.0%
Init. Brake Force	*0(OFF)%
Max. Brake Force	*90.0%
Fwd. Drag Brake Force	*10.0%
Fwd. Drag Brake Response	*1.0ms
Rev. Drag Brake Force	*100.0%
Rev. Drag Brake Response	*1.0ms
Brake Freq.	*4.0KHz

MENU	
SAVE	DEFAULT
Turbo	
Turbo Timing	32.0deg
Turbo On Rate	45.0deg/0.1s
Turbo Off Rate	*64.0(instant...)
Turbo Delay	0.05s
Race Mode	*modify

MENU	
SAVE	DEFAULT
Boost	
Boost Timing	8.0deg
Boost Activation	*throttle
Boost Trigger Pos.	*60.0%
Boost RPM Threshold	*18.0kr/min
Initial Angle	*1.0deg
Boost On Rate	45.0deg/0.1s
Boost Off Rate	64.0(instant...)



9. TP_ESC_BTV1 APPS download link QR code:

Android APPS Version:

IPhone APPS Version:



Or refer to below website link:

Android APPS Version:

<https://play.google.com/store/apps/details?id=com.inrico.blemodel>

I-Phone APPS Version:

<https://apps.apple.com/hk/app/tp-esc-btv1/id6444782581>



10. Troubleshooting Table:

<i>Symptom</i>	<i>Cause</i>	<i>Action to take</i>
No motor and servo functions	Wiring problem	Check wire and connectors
	Wrong polarity when connecting the BEC wire to the receiver	Correct the polarity when connecting the BEC wire to the receiver
	Transmitter, Receiver or Battery defective	Replace the components one by one
	Speed control defective	Send for repair
No motor function, but servo is working	Wiring problem	Check wire and connectors
	Sensor wiring defective/missing	Change other wire
	Motor defective	Change other motor
	Speed control defective	Send for repair
While accelerating, motor stutters	Sensor wiring defective	Replace the wire
	Motor or Sensor board defective	Change other motor or sensor board
	Power Capacitor failure	Replace the power capacitor
	Radio interference	Change the components location
	Speed control defective	Send for repair
Motor runs at constant slow speed and never stops	Transmitter settings changed after setup	Repeat set up procedure
	Humidity/water in speed control	Dry the speed control
Radio Interference	Transmitter batteries empty	Replace transmitter batteries
	Bad battery connection	Check wire connection
	Receiver, transmitter or servo defective	Replace the components one by one
	Receiver or antenna too close to power wires of motor and battery	Change the components location



11. Warning Notes:

- Please read the following instructions carefully before starting to use the unit. For those users that do not have experience to use it, please seek help from the professional users.
- Please make sure the voltage applied to the unit is in the operating range and the battery + and – sign should be connected properly to the power cord of the unit. If battery +, - is reversed to connect to the unit, the unit will be burnt out.
- In case there is an abnormal operation in the unit, please turn off the unit and go to section 4 to setup the speed control again.

12. 45 days Warranty Services:

All products are manufactured according to the highest quality standards. Team Powers guarantees this product to be free from defects in materials or workmanship for 45 days from the original date of purchase verified by sales receipt. This limited warranty doesn't cover incorrect installation, operations that are instructed to users, damaged by crash or any natural disaster.

This also applies the below things on:

- ⊙ Cut off the original power plug
- ⊙ Receiver wire and/or switch wire damaged
- ⊙ Mechanical damage of the case
- ⊙ Mechanical damage of electronic components/PCB
- ⊙ Humidity/Water inside the speed control
- ⊙ Soldered on the PCB (except on solder pads)
- ⊙ Connected speed-control with reversed polarity

Before you send in this product for repair, please try to eliminate all other possibilities or improper handling by checking all other components in your model and the trouble shooting guide. If the products are sent in for repair, which do operate perfectly, we have to charge a service fee according to our pricelist.

With sending in this product, the customer has to advise Team Powers if the product should be repaired in either case. If there is neither a warranty nor guarantee claim, the inspection of the product and the repairs may be charged with a fee at the customers expense according to our price list. A proof of purchase including date of purchase needs to be included. Otherwise, no warranty



can be granted. For quick repair-and return service, please add your address and detailed description of the malfunction.

If Team Powers are unable to service those defective products that are no longer exist in the market, we shall provide you with a product that has at least the same value from one of the successor series.

The specifications like weight, size and others should be seen as in this user guideline. Due to ongoing technical improvements, which are done in the interest of the product, Team Powers does not take any responsibility for the accuracy of these specs.

Distributor Service:

- ⊙Package your product with sales receipt together with the detailed description of malfunction.
- ⊙Send parcel to your national Team Powers dealer/distributor.
- ⊙Distributor repairs or exchanges the product.
- ⊙Shipment back to your usually by COD (cash on delivery), but this is subject to the general policy of your national Team Powers dealer/distributor.

If any further information need upon reviewing the instruction, please feel free to contact **enquiry@rc-explorer.com**. For more about Team Powers product information, please go to <http://www.team-powers.com>.